



# ROTABLOC

## Rotary UPS & Rotary Power Conditioners

Outstanding Voltage Conditioning with Total Power Failure Protection



Power You Can Rely On

# Rotabloc RBT Overview

The Rotabloc system utilizes simple, efficient, conventional electrical and mechanical components while being highly robust. The system consists of a standard synchronous generator with no special windings and a simple steel flywheel. Bearing life is extended and maintenance is reduced due to its low speed shaft.

## Function

IEM's Rotabloc provides power quality that surpasses uninterrupted power. It not only offers protection from more or less long interruptions, but it prevents your load from being affected by all network imperfections.

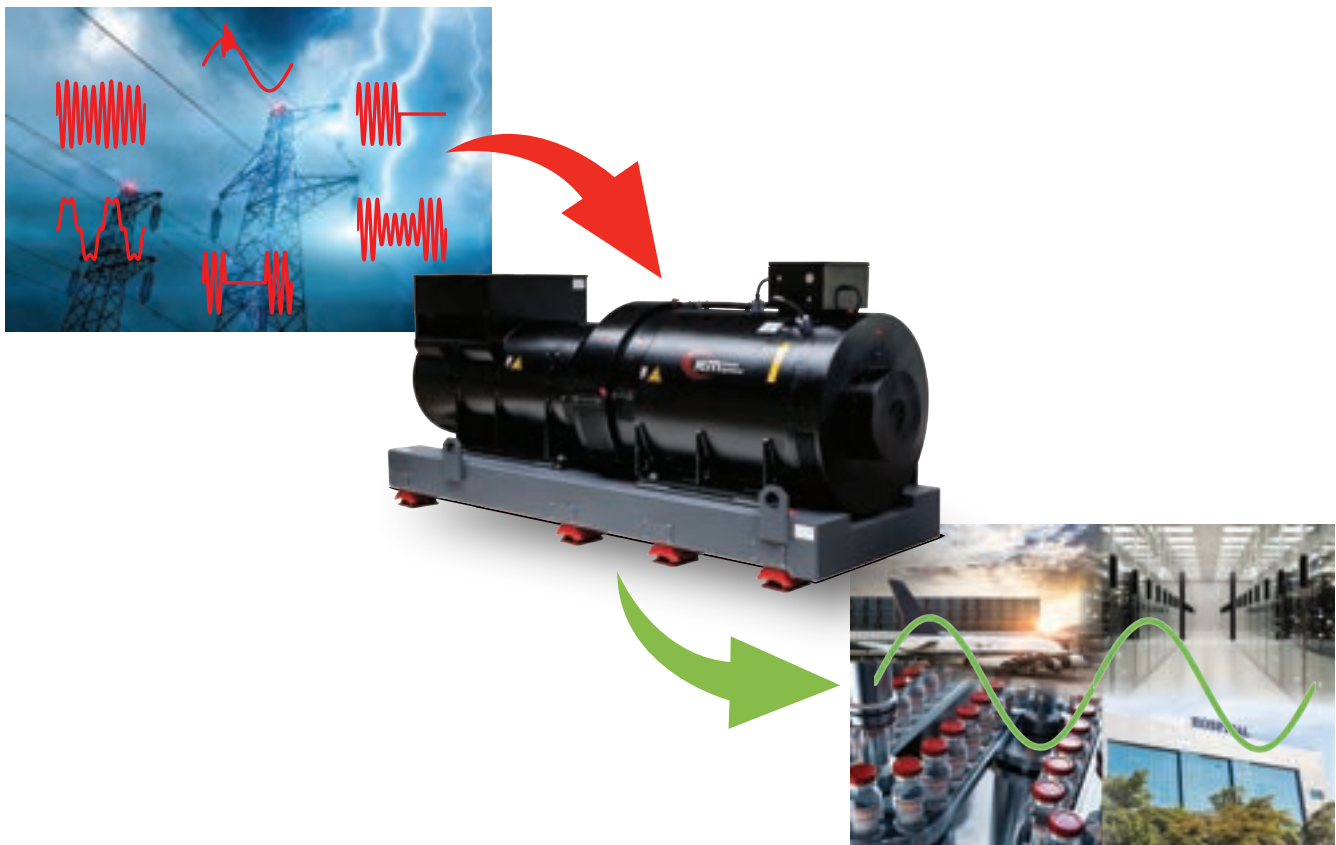

In addition to supplying your load in an extremely stable manner (precise voltage and frequency), the Rotabloc offers:

- **High Short Circuit fault clearing Power (15-20 x In)**
- **Harmonics Currents Filtering (~ 95%)**
- **Power Factor Compensation (Mains side Power Factor 0.99)**

All these functions are performed both at low voltage and medium (high) voltage and at 50Hz or 60 Hz.

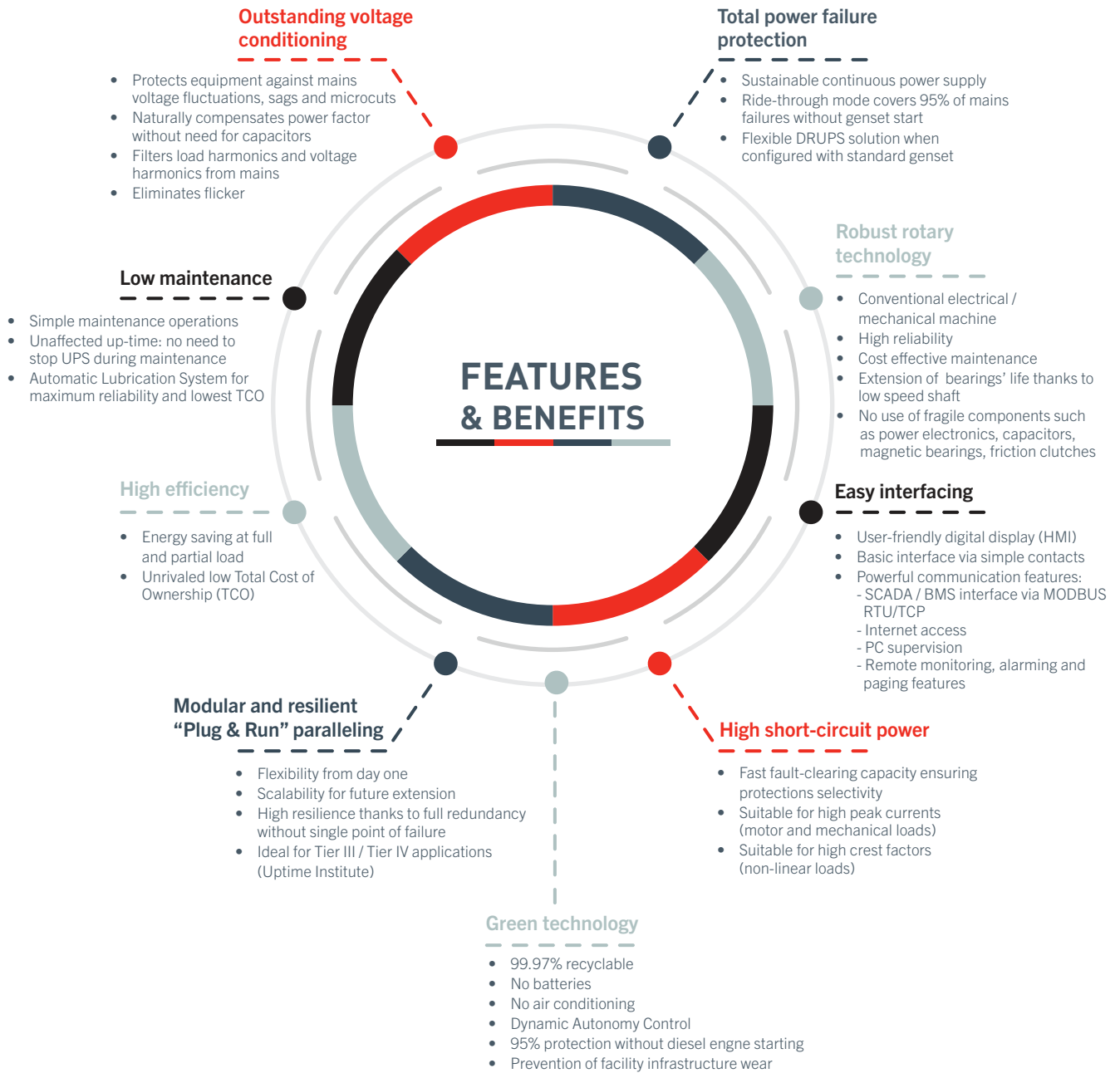

# Configuration

## Single Module

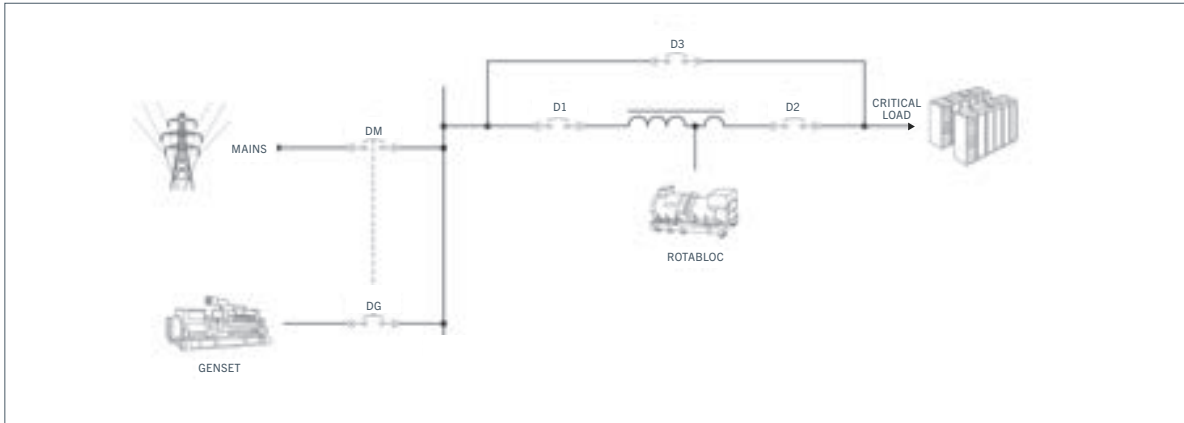

## Parallel installation

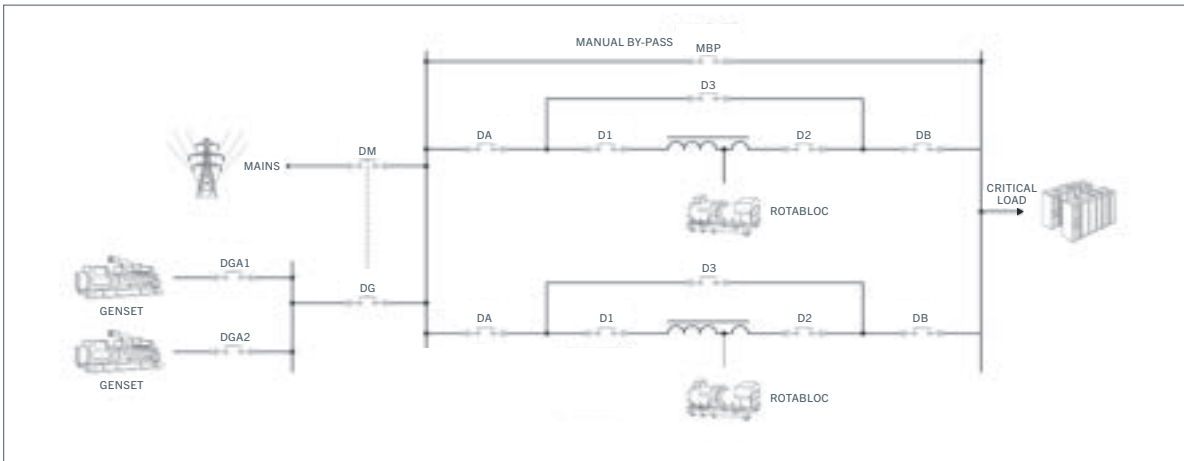

## Medium Voltage

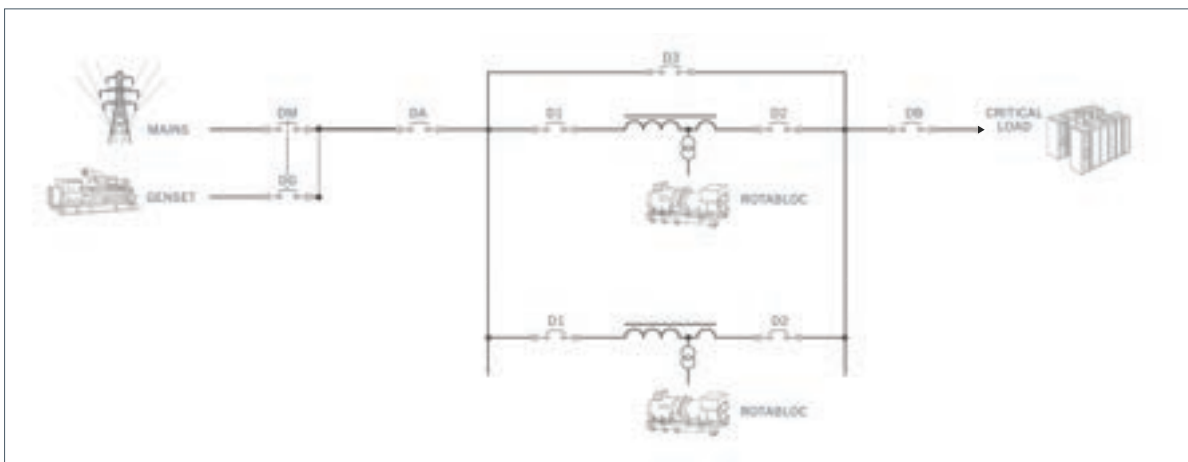

# Range

## Rotary UPS

ROTARY UPS 50Hz	POWER (kVA)	POWER (kW)
RBT - 400	400	320
RBT - 500	500	400
RBT - 630	630	504
RBT - 800	800	640
RBT - 1000	1000	800
RBT - 1100	1100	880
RBT - 1250D	1250	1000
RBT - 1600D	1600	1280
RBT - 1750D	1750	1400
RBT - 2000D	2000	1600
RBT - 2200D	2200	1760

ROTARY UPS 60Hz	POWER (kVA)	POWER (kW)
RBT - 400	400	320
RBT - 500	500	400
RBT - 600	600	480
RBT - 630	630	504
RBT - 800	800	640
RBT - 1000	1000	800
RBT - 1200D	1200	960
RBT - 1250D	1250	1000
RBT - 1600D	1600	1280
RBT - 1750D	1750	1400
RBT - 2000D	2000	1600

## Power Conditioner

POWER CONDITIONER 50Hz	POWER (kVA)	POWER (kW)
RBQ - 1300	1300	1040
RBQ-1600	1600	1280
RBQ-2750D	2750	2200

POWER CONDITIONER 60Hz	POWER (kVA)	POWER (kW)
RBQ-1200	1200	960
RBQ-1600	1600	1280
RBQ-1900	1900	1520
RBQ-2400D	2400	1920
RBQ-2600D	2600	2080
RBQ-3300D	3300	2640
RBQ-3800D	3800	3040

IEM Power Systems delivers **high reliability and efficiency** —  
ensuring **complete protection** of critical electrical loads,  
and **low cost of ownership**.

## Protecting Critical Power for Over 25 Years

<b>Manufacturing</b>	<b>Data Centres</b>
<b>Pharma</b>	<b>Telecommunications</b>
<b>Food &amp; Beverage</b>	<b>Government</b>
<b>Oil &amp; Gas</b>	<b>Defense</b>
<b>Healthcare</b>	<b>Research</b>
<b>Airports</b>	<b>Banking</b>

### IEM Power Systems (IEMPS)

IEM Power Systems is a subsidiary of Industrial Electric Mfg. (IEM), North America's largest independent full-line manufacturer of electrical distribution and power quality equipment. IEM Power Systems designs and builds innovative electrical power systems worldwide. With facilities in the U.S. and Europe, we are able to serve businesses worldwide with innovative solutions to meet their facility's needs. Our quality products and superior service offering allows us to continually serve customers who value quality and reliability.



#### Belgium

IEM Power Systems™  
Cour Lemaire, 16  
B-4651 Battice (Belgium)  
dir +32.87.32.40.50

#### Corporate Headquarters

Industrial Electric Mfg.™  
48205 Warm Springs Blvd  
Fremont CA 94539  
dir +1.510.656.1600

#### Jacksonville

Industrial Electric Mfg.™  
3600 Port Jacksonville Pkwy  
Jacksonville FL 32226  
dir +1.904.365.4444

#### Vancouver Office

Industrial Electrical Mfg.™  
3261 192 St.  
Surrey BC V3Z 1A7  
dir +1.888.436.8668

[www.iemps.com](http://www.iemps.com)

ISO 9001 Certified